

# P10387 SEN-BRI823-B-D

## High/Low/Off Passive Infrared Fixture Integrated Outdoor Sensor

Hold off setpoint with automatic calibration option for convenience and added energy savings



SEN-BRI823-B-D



(DIP Switch)



RC-100 (OPTIONAL)

IP65 rated for wet locations

Multiple mounting options for easy installation

Fully adjustable high and low dimmed light levels; optional dusk to dawn control



IP65

### Product Overview

### Description

The SEN-BRI823-B-D mounts in an outdoor lighting fixture and provides multi-level control based on motion and/or daylight contribution. It controls 0-10 VDC LED drivers or dimming ballasts, and is rated for wet and cold locations. All control parameters are adjustable via a wireless configuration tool capable of storing and transmitting sensor profiles.

### Applications

The slim, low-profile SEN-BRI823-B-D is designed for installation inside the bottom of a light fixture body. When fully assembled and installed in an IP65-rated fixture, the PIR sensor module parts are IP65 outdoor rated. The sensor is ideal for areas such as parking facilities, gas stations, pedestrian pathways and warehouses. A choice of two PIR Lens ensures complete coverage for mounting heights up to 40'.

### Features

- Provides line voltage On/Off switching and 0-10VDC dimming control
- Works with ballasts or LED drivers
- High and low modes fully adjustable from 0 to 10V
- Time delay from 10seconds to 60 minutes
- Optional cut off delay
- Adjustable ramp up and fade down times
- Optional daylighting setpoints feature automatic calibration, or permit manual adjustment.
- Polycarbonate, flame retardant, UV resistant, impact resistant.
- UL773A and FCC

### Specifications

Power supply	120-277VAC
Maximum load @ -40°F ~ +158°F (-40°C ~ +70°C)	Resistive/Halogen - 800W@120V/1200W@277V Fluorescent Ballast/CFL - 660W@120V/1200W@277V Electronic Ballast (LED) - 5A@120V/5A@277V
Dim control output	0-10V, max. 25mA sinking current
Detection radius/angle	30ft @ 40ft Height/360°
Mounting height	Max 24ft. @LW1      Max 40ft. @LS2
Remote range	50ft. (15m) indoor, no backlight
Humidity	Max. 95% RH
Temperature	-40°F ~ +158°F (-40°C ~ +70°C)

### Corridor Function

This function inside the motion sensor to achieve tri-level control, for some areas which require a light change notice before switch-off. The sensor offers 3 levels of light: 100%-->dimmed light (natural light is insufficient)-->off; and 2 periods of selectable waiting time: motion hold-time and stand-by period; Selectable daylight threshold and freedom of detection area.

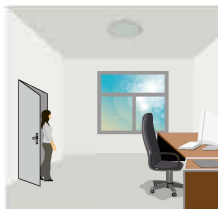

With sufficient natural light, the light does not switch on when presence is detected.

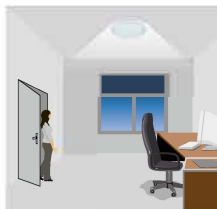

With insufficient natural light, the sensor switches on the light automatically when presence is detected.

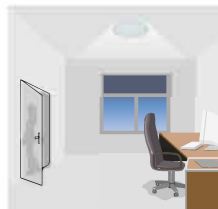

After hold-time, the light dims to stand-by level if the surrounding natural light is below the daylight threshold.

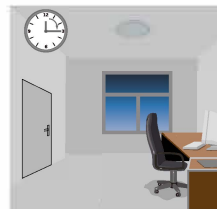

Light switches off automatically after the stand-by period elapses.

Note:if you choose STAND-BY DIM is 0,the stand-by period is 0,it is ON/OFF function.

# Smart Photocell Function

open the smart photocell sensor by push  when remote control is in setting condition.

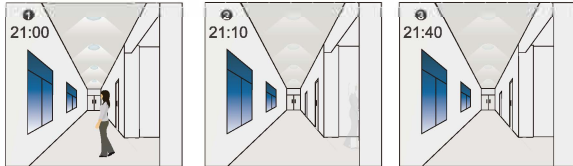

The light switches on at 100% when there is movement detected. The light dims to stand-by level after the hold-time. The light remains in dimming level at night.

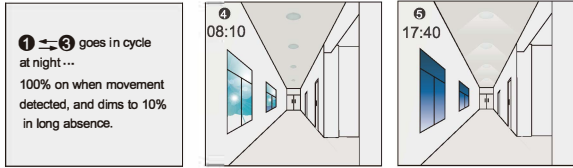

1 goes in cycle at night ... 100% on when movement detected, and dims to 10% in long absence. When the natural light level exceeds setpoint off to light, the light will turn off even if when the space is occupied. The light automatically turns on at 10% when natural light is insufficient (no motion).

Settings on this demonstration:  
 Hold-time: 10min  
 Setpoint on: 50lux  
 Setpoint off: 300lux  
 Stand-by Dim: 10%  
 Stand-by period: +∞  
 (when the smart photocell sensor open, the stand-by time is only +∞)

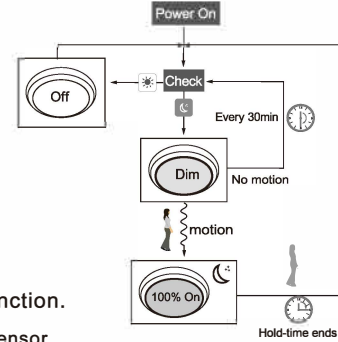

## Difference between Corridor Function and Smart Photocell Function.

1. In corridor function, the daylight sensor as threshold to assist motion sensor, in Photocell function, the daylight sensor works independently to motion sensor.
2. Turn On light by detect motion when natural light is insufficient for corridor function, turn on light by natural light level exceeds setpoint on to light, do need to detect motion, for smart photocell function.
3. Turn off light by stand-by time for corridor function, Turn off light by natural light level lower than setpoint off of light for smart photocell function.

# Dimensions & Mounting

## Sensor Dimensions

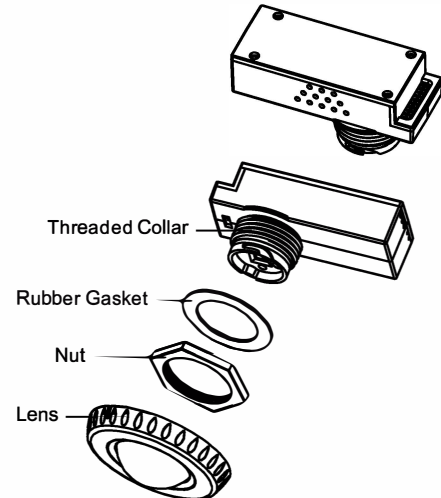
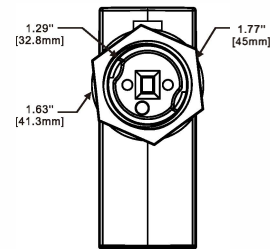
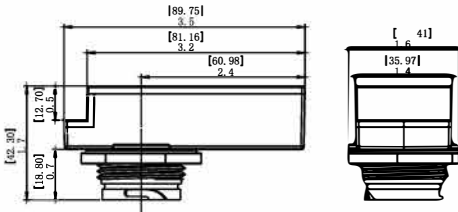

## Sensor Mounting

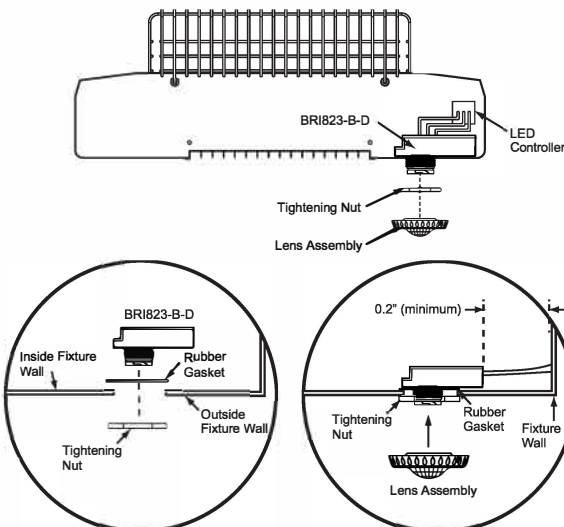

Fixture Integrated Microwave Sensor

# Coverage L3

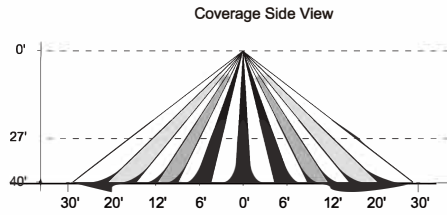

L3: 360° Coverage

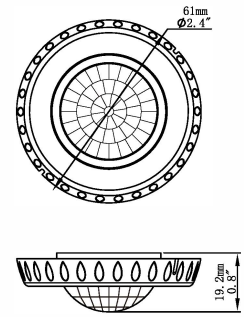
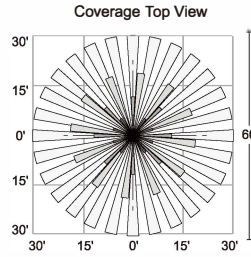

# L4

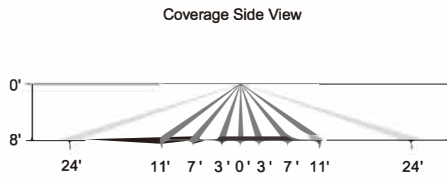

L4: 360° Coverage

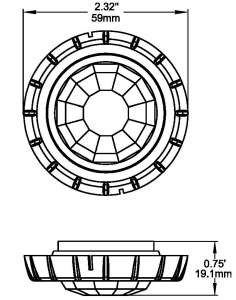
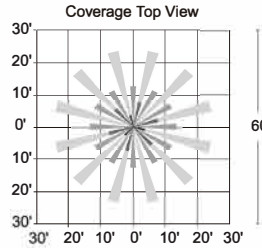

# Wiring

SEN-BRI823-B-D wiring with dimming ballast or LED driver.  
Dimming Driver

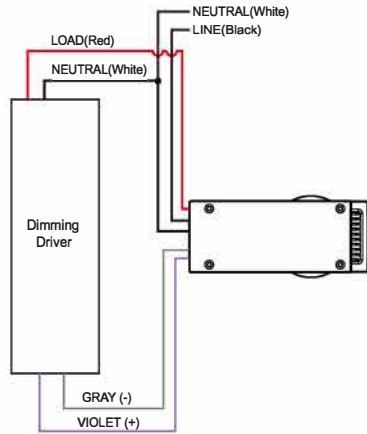

SEN-BRI823-B-D wiring with non-dimming ballast or LED driver.  
Non-Dimming Driver

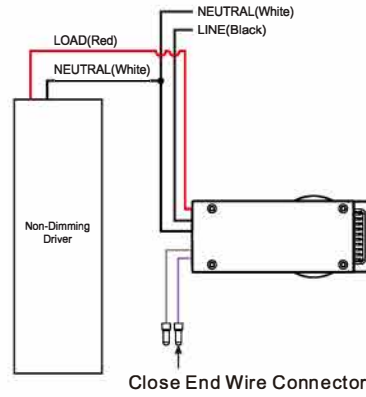

# Ordering Information

Catalog No.	Color	Description
<input type="checkbox"/> BRI823-B-D	White/Black	Dimming PIR Sensor
<input type="checkbox"/> L3	White/Black	360° lens, maximum coverage 60' diameter from 8'-40' height
<input type="checkbox"/> L4	White/Black	360° lens, maximum coverage 48' diameter from 8'-20' height
<input type="checkbox"/> RC-100	Black	Remote control Battery : AAA x 2